

## Attack basket for hoses

Basket for hoses to store, transport and deploy 3 x 15 meters of flat hose with 25 mm diameter. Depending on the hose type, it can be up to 25 meters per hose.

This product is robust and made in aluminium alloy, with carrying strap and crank to roll the hoses. It can be delivered with or without hoses.

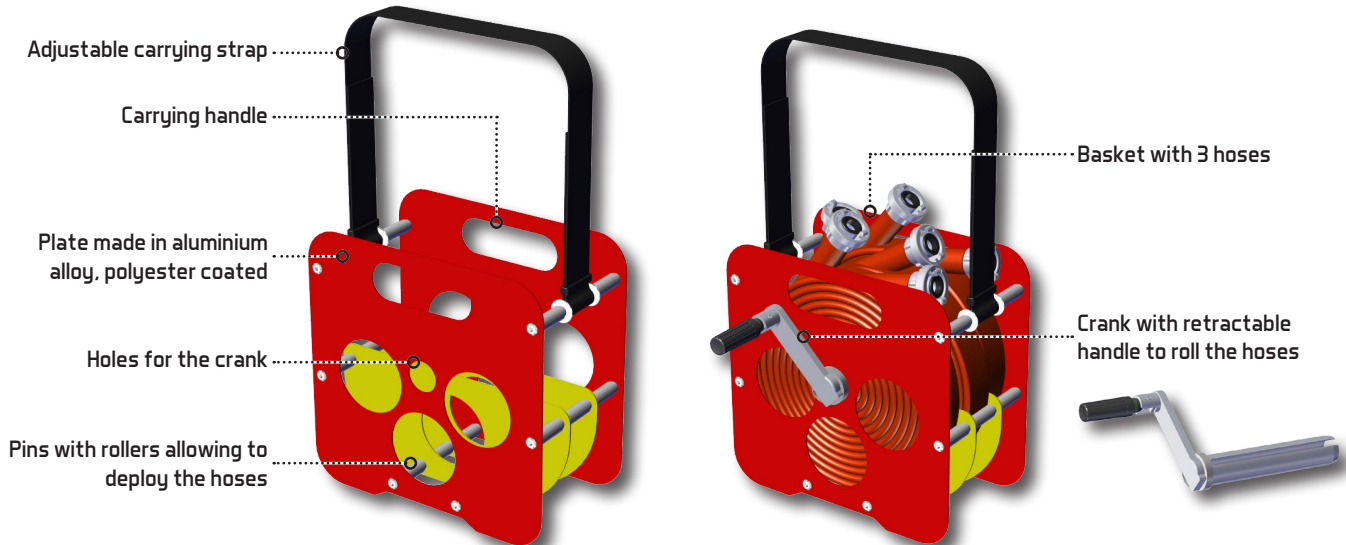

### CHARACTERISTICS

Reference	• 39476
<b>Construction</b>	
Body	• Aluminium alloy, polyester coated
Crank handle	• Polypropylene
Strap	• Polyester canvas
Screws	• Stainless steel
<b>Mechanical characteristics</b>	
Capacity	• 3 x 15 meters, DN25 - depending on the hose type, it can be up to 25 meters per hose <b>Note:</b> According to the reference, the basket is sold with or without hoses with or without couplings
Weight	• 2,44 kg

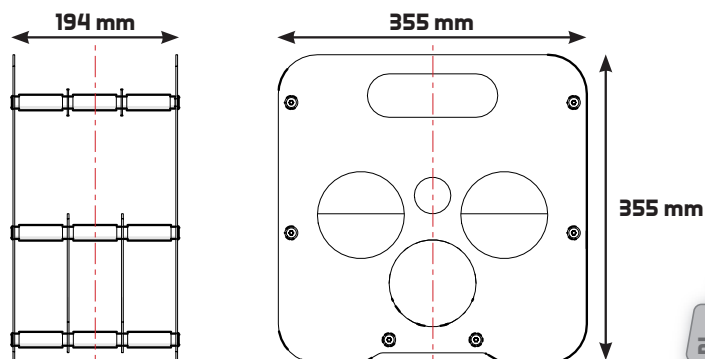

## Attack basket for hoses

### DEPLOYMENT PRINCIPLES



- 1 - The basket is fastened in a compartment of the vehicle, hoses are double-rolled.
- 2 - Connect the hoses between them, one end connected to the water supply, the other to the nozzle.
- 3 - Hoses unroll when the nozzle operator is moving away from the vehicle. A person can help to unroll the hoses at the truck.

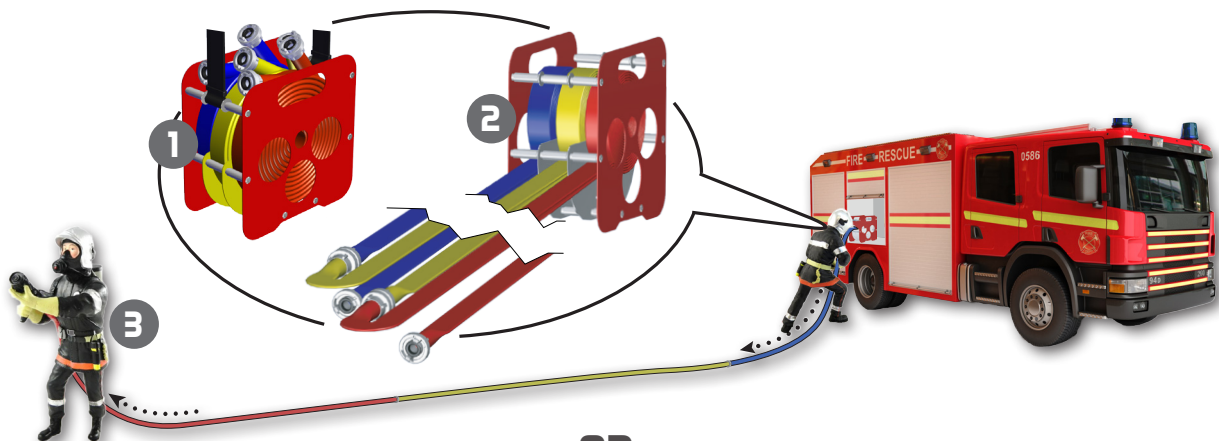

OR

- 1 - Connect the hoses between them, one end connected to the water supply, the other to the nozzle.
- 2 - The nozzle operator carries the basket on the shoulder and moves away from the vehicle.
- 3 - The hoses are being run out from the basket, a second person can assist to flake out the remainder of hose from the basket as a reserve.

